

34		WATER TANK	W0926 42 GAL	1
33		WATER HEATER		1
32		WASTE TANK-3-RH	21053	1
31		WASTE TANK-2-RH	21054	1
30		TOILET	13794	1
28		SINK SST 15X15		1
27		SHOWER		1
26		SHELF VANITY		1
25		SEWER HOSE COMP.		1
24		SALEM VENT		1
23	14619	ROOF VENT		1
22		RANGE HOOD		1
21		RANGE		1
19		OUTLET	120V 15A INTERIOR	3
18		MOTORBASE	30 AMP	1
17		MIRROR		1
16		MICROWAVE	Dometic	1
15		LP TANKS W-TRAY	20#	1
14		LIGHT - FLUORESCENT	12" 12V	1
13		LIGHT - FLUORESCENT	18" 12V	1
12		FRIG	2.7 CU FT	1
11		FIRE EXTINGUISHER		1
9		COUNTERTOP - FLIP UP		1
8	12451	CONVERTER - 12VDC	55 AMP	1
7		CABINET MICRO OH		1
6		CAB STORAGE T2		1
5		CAB OVERHEAD T2		1
4		CAB LINEN S3		1
3		CAB BASE T2		1
2		BREAKER BOX	30 AMP	1
1		BATTERY BOX PLASTIC	BATTERY - 540 COLD CRANK	1
ITEM NO.	PartNo	PART NUMBER	DESCRIPTION	QTY.

TITLE:  
T2 PACKAGE

DRAWN BY: JRS DATE: 1.31.11 VIN # REV.

FILE NAME: T2 SCALE:1:14 DATE PRINTED: 1/31/2011 SHEET 1 OF 5

ALL LOCATIONS ARE NOMINAL UNLESS CRITICAL DIMENSIONS ARE SPECIFICALLY NOTED

PROPRIETARY AND CONFIDENTIAL: THE INFORMATION CONTAINED IN THIS DRAWING IS THE SOLE PROPERTY OF THE ALUMINUM TRAILER COMPANY. ANY REPRODUCTION IN PART OR AS A WHOLE WITHOUT THE WRITTEN PERMISSION OF THE ALUMINUM TRAILER COMPANY IS PROHIBITED.



REV.	DESCRIPTION	DATE	APPROVED
	REVISION TABLE		

DWG PATH: X:\Templates, Options, Extrusions, etc\Options\T-PKG\

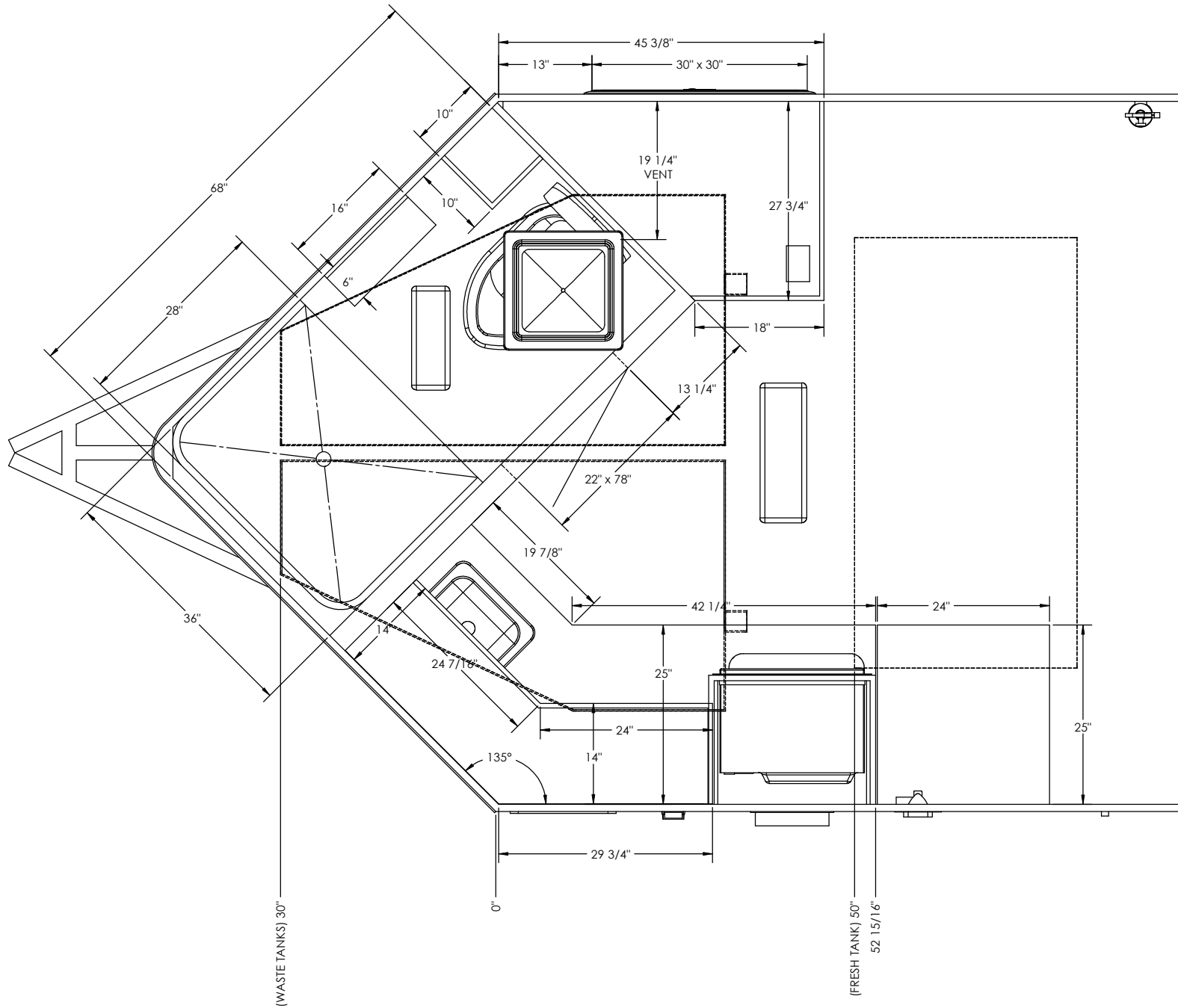

TITLE: T2 PACKAGE			
DRAWN BY: JRS	DATE: 1.31.11	VIN #	REV.
FILE NAME: T2			
SCALE: 1:10	DATE PRINTED: 1/31/2011	SHEET 2 OF 5	

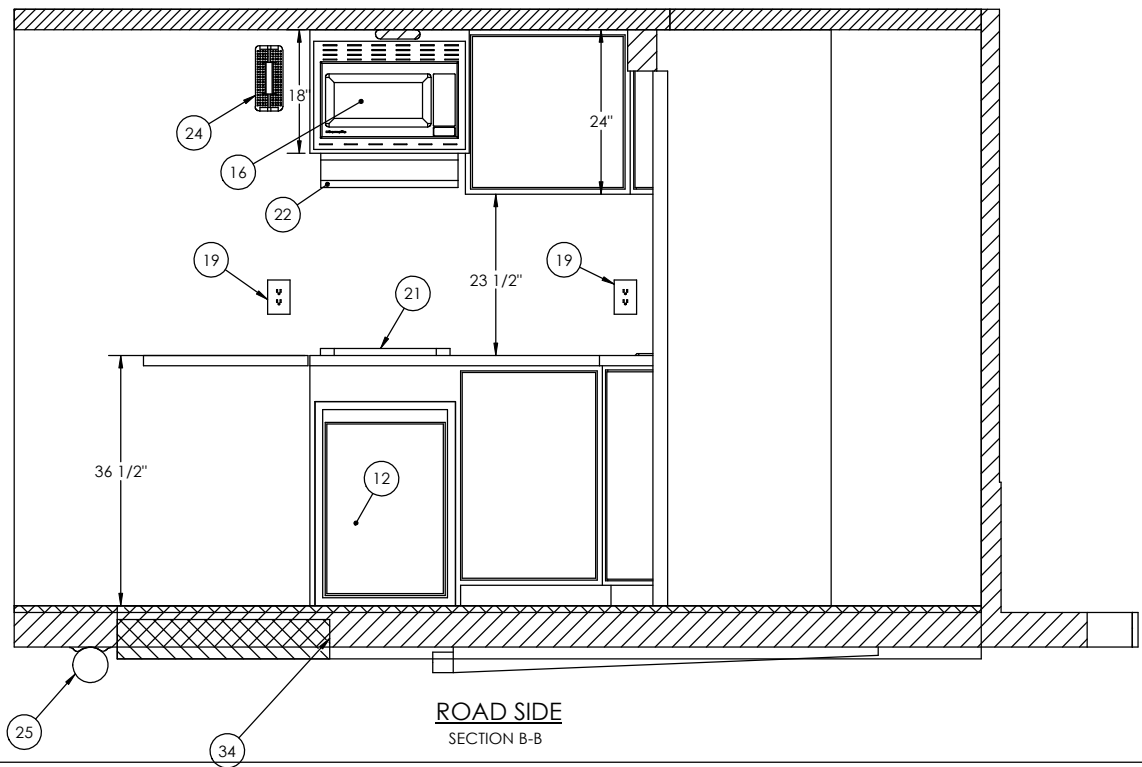
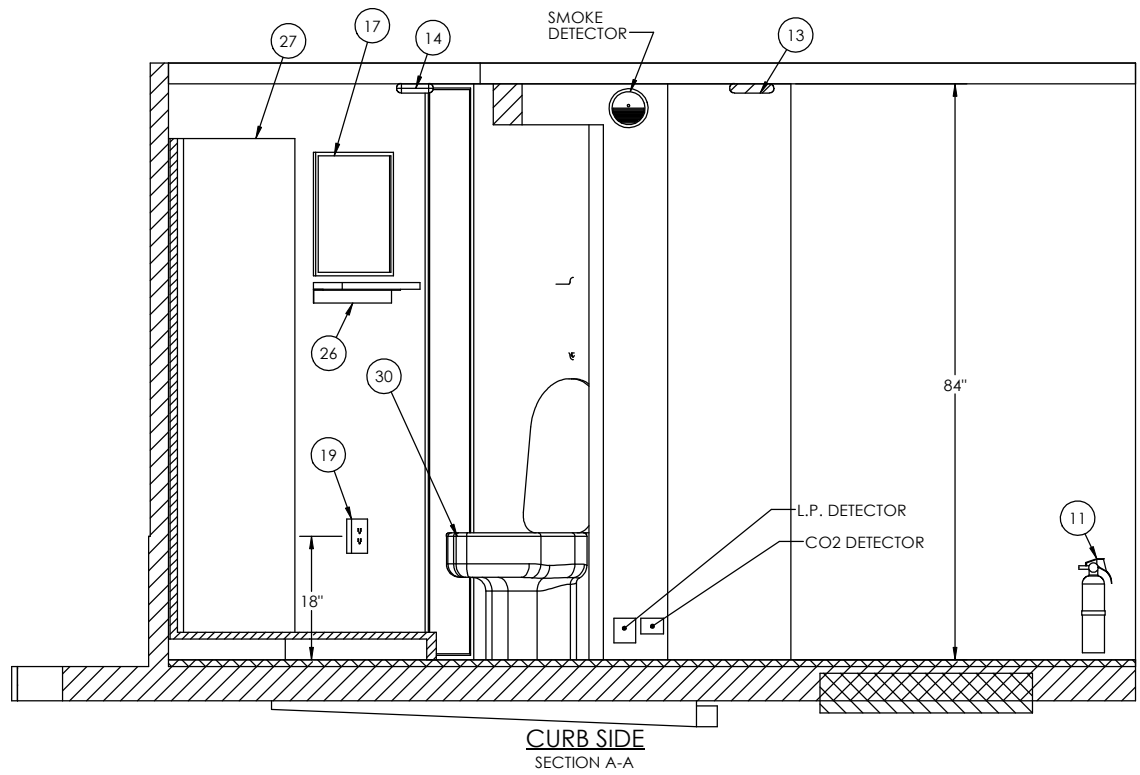

	TITLE: T2 PACKAGE			REV.
	DRAWN BY: JRS	DATE: 1.31.11	VIN #	
	FILE NAME: T2			
	SCALE: 1:14	DATE PRINTED: 1/31/2011	SHEET 3 OF 5	

**OVERHEAD**

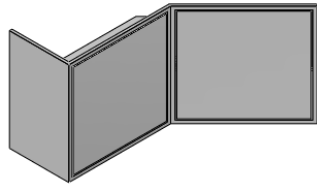
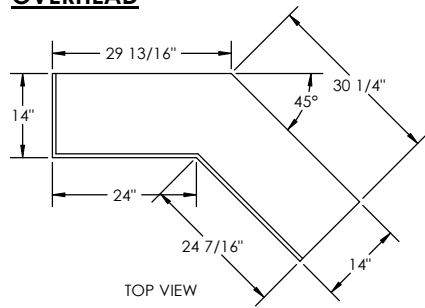

TOP VIEW

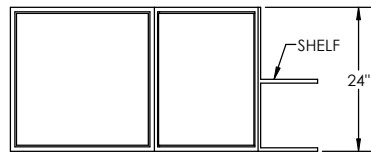

FRONT VIEW

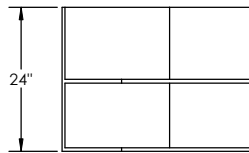

SIDE VIEW

**BASE**

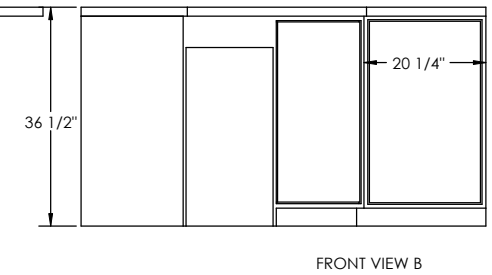
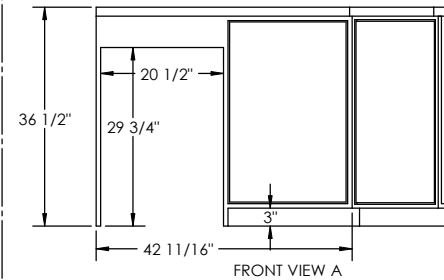
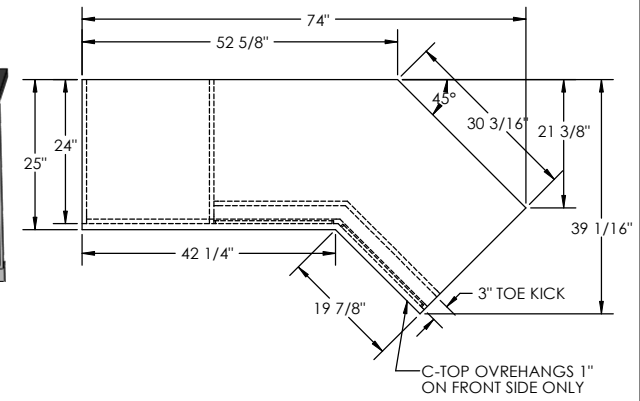
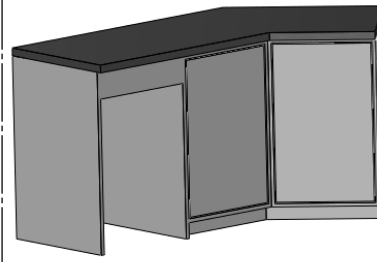

**STORAGE CABINET**

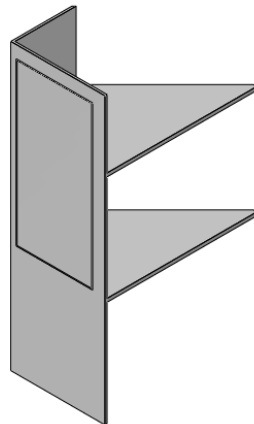
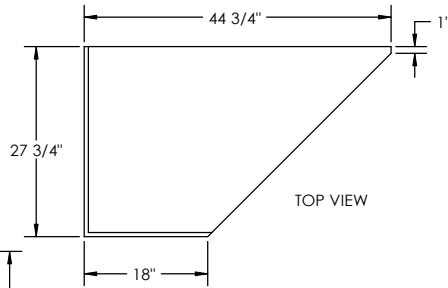
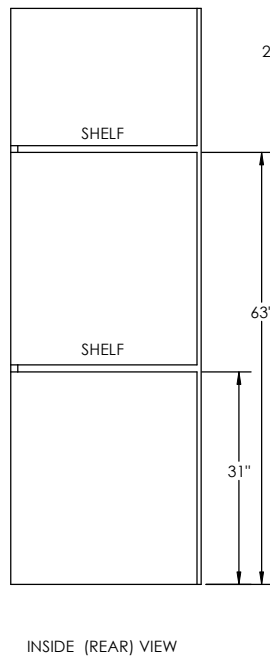
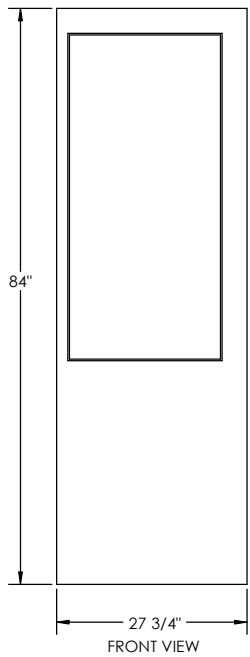

**LINEN**

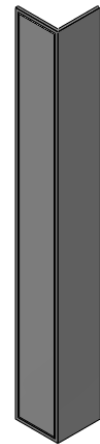
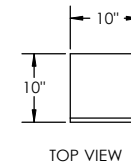
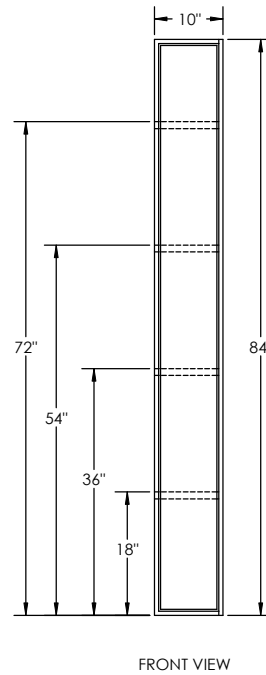

TITLE: T2 PACKAGE			
DRAWN BY: JRS	DATE: 1.31.11	VIN #	REV.
FILE NAME: CAB BASE T2			
SCALE: 1:14	DATE PRINTED: 1/31/2011	SHEET 4 OF 5	

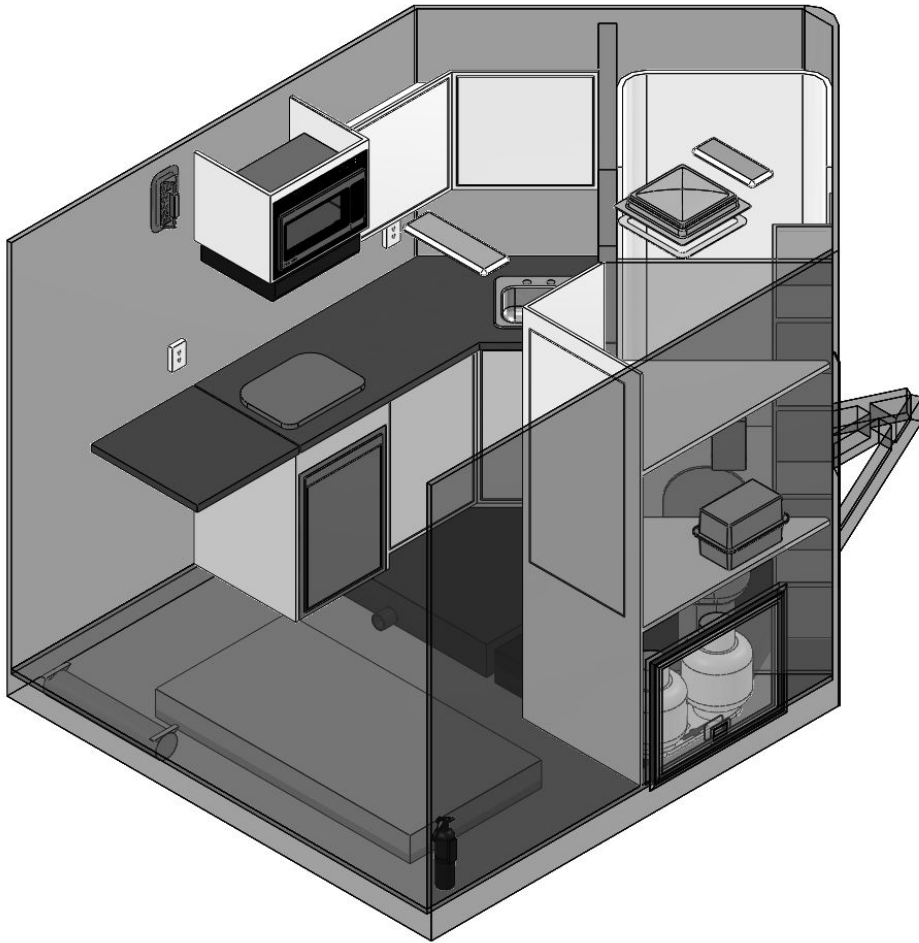

CURB SIDE VIEW

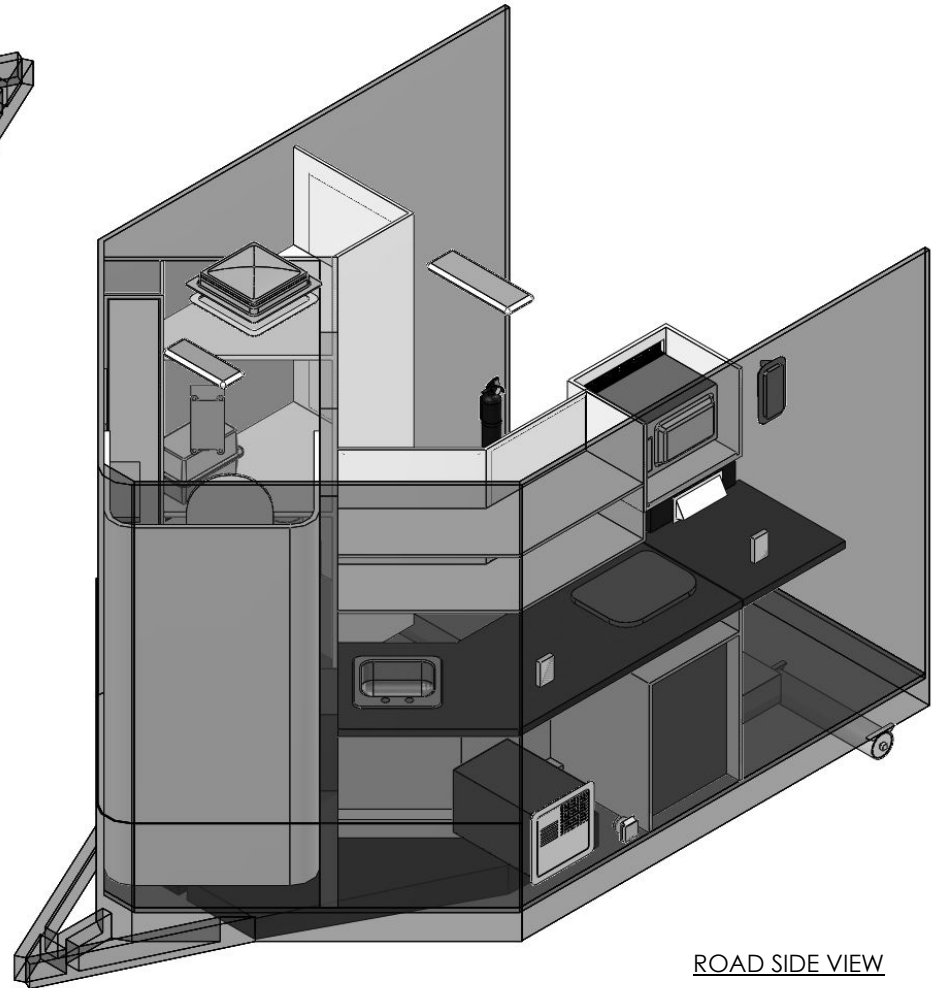

ROAD SIDE VIEW



TITLE: <b>T2 PACKAGE</b>				REV.
DRAWN BY: JRS	DATE: 1.31.11	VIN #		
FILE NAME: T2				
SCALE: 1:16	DATE PRINTED: 1/31/2011	SHEET 5 OF 5		