

52		WATER TANK	W1306 94GAL.	1	27		LIGHT - FLUORESCENT	18" 12V	6
51		WATER HEATER		1	25		LADDER GN		1
50		WASTE TANK	H1026 45.5 GAL	2	24		GRAB HANDLE	GRAB HANDLE - LIGHTED	1
49		TV SAMSUNG	LN26C350D1D	1	23		FURNACE	35K BTU (SH-35)	1
48		TOILET	13794	1	22		FRIG VENT		2
47		TABLE - SOFA		1	21		FRIG	6 CU FT	1
46		STEP - FLIP OUT	32"	1	20		FIRE EXTINGUISHER		1
45		SOFA		1	18		CONVERTER - 12VDC	55 AMP	1
44		SLIDEOUT-14' LQ		1	17		CAB TV OH		1
43		SINK SST 17 X 22		1	16		CAB TOILET OVERHEAD		1
42		SINK SST 13.25 x 10.5 x 5		1	15		CAB RANGE-MICRO OH		1
41		SHOWER ANGLE	SHOWER CORNER GTS-3434	1	14		CAB PANTRY		1
40	14619	ROOF VENT		2	13		CAB MEDICINE		1
39		RANGE HOOD		1	12		CAB LR WARDROBE		1
38		RANGE		1	11		CAB LAV BASE		1
35		OUTLET	COAX - EXTERIOR INLET	1	10		CAB KITCHEN SINK BASE		1
34		OUTLET	ANTENNA AMPLIFIER (12V & COAX)	1	9		CAB FRIG		1
33		OUTLET	120V 15A EXTERIOR	1	8		CAB BEDROOM SHIRT CLOSET		2
32		OUTLET	120V 15A INTERIOR	8	7		CAB BEDROOM OH		1
31		MIRROR - FRAMED		1	6		CAB BEDROOM HEADBOARD		1
30		MICROWAVE	Dometic	1	5		CAB BEDROOM CORNER		1
29		MATTRESS		1	4		CAB BEDROOM CORNER		1
28		LP TANKS	20#	1	3		BATTERY BOX PLASTIC	BATTERY - 540 COLD CRANK	2
27				1	2		ANTENNA OMNIDIRECTIONAL		1
25				1	1		14' LQ		1

BOM TABLE

BOM TABLE

ALL LOCATIONS ARE NOMINAL UNLESS CRITICAL DIMENSIONS ARE SPECIFICALLY NOTED



TITLE: 14' LQ PACKAGE

REV.	DESCRIPTION	DATE	APPROVED
	REVISION TABLE		

PROPRIETARY AND CONFIDENTIAL: THE INFORMATION CONTAINED IN THIS DRAWING IS THE SOLE PROPERTY OF THE ALUMINUM TRAILER COMPANY. ANY REPRODUCTION IN PART OR AS A WHOLE WITHOUT THE WRITTEN PERMISSION OF THE ALUMINUM TRAILER COMPANY IS PROHIBITED.

DRAWN BY: JRS	DATE: 1.12.11	VIN #	REV.
FILE NAME: 14'LQ	SCALE: 1:18	DATE PRINTED: 1/12/2011	SHEET 1 OF 5

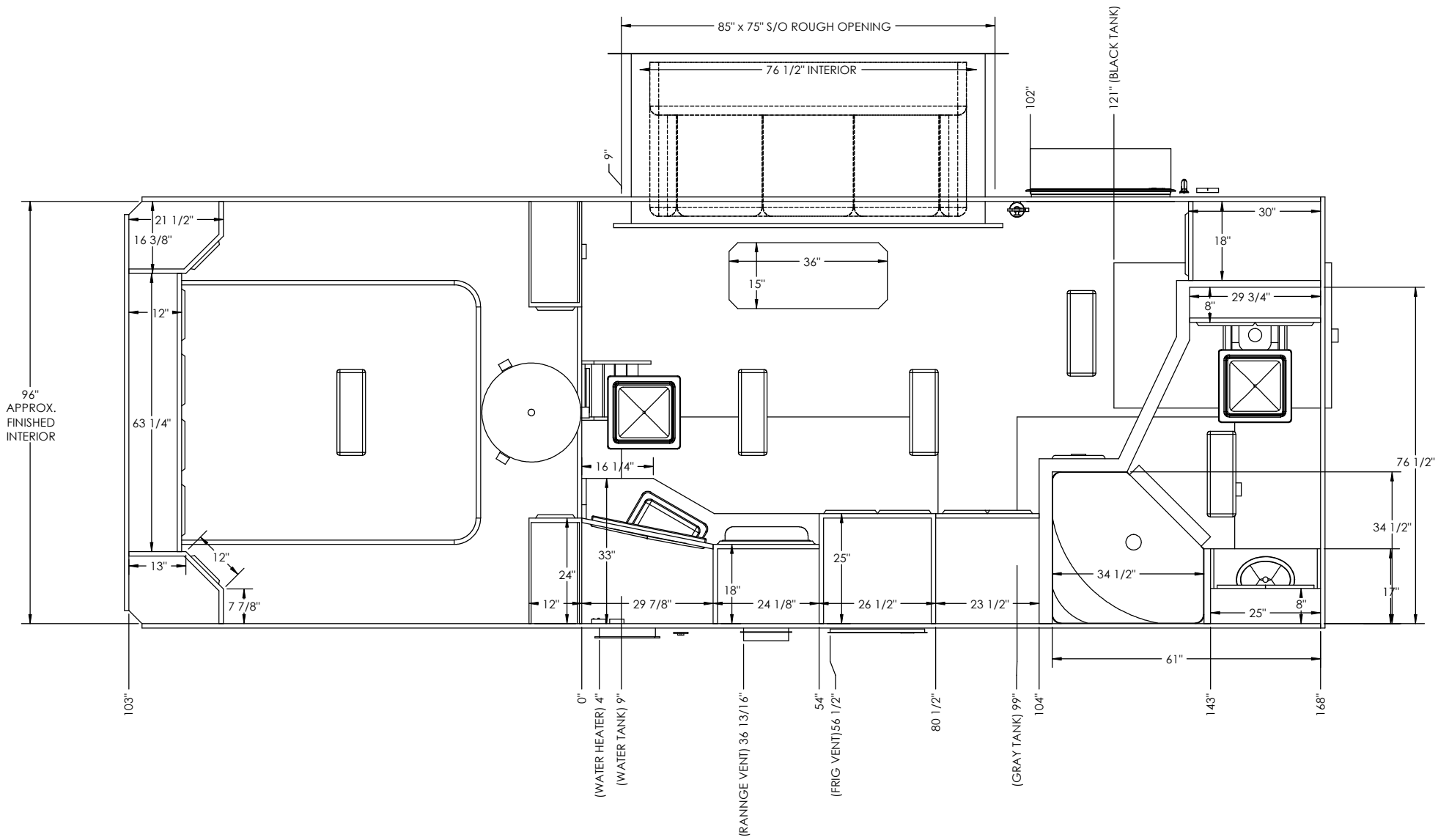

TITLE: 14' LQ PACKAGE			
DRAWN BY: JRS	DATE: 1.12.11	VIN #	REV.
FILE NAME: 14'LQ			
SCALE: 1:16	DATE PRINTED: 1/12/2011	SHEET 2 OF 5	

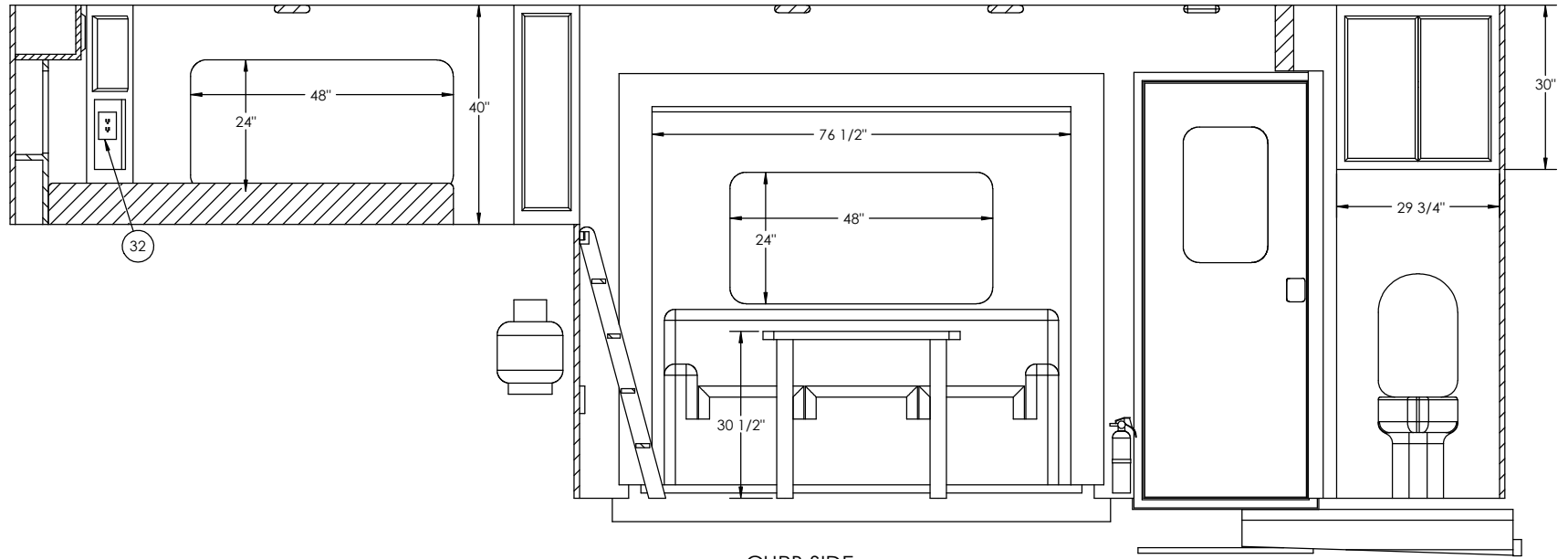

CURB SIDE
SECTION A-A

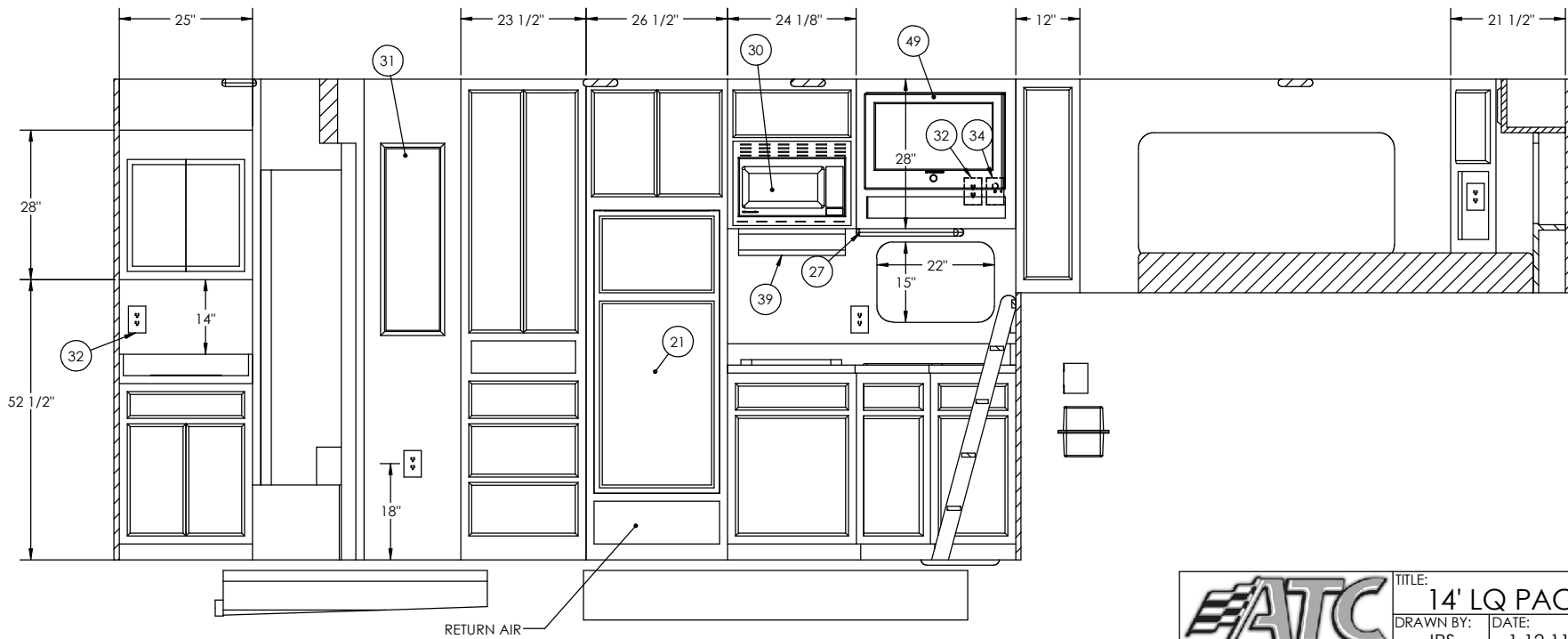

ROAD SIDE
SECTION B-B



TITLE: 14' LQ PACKAGE			
DRAWN BY: JRS	DATE: 1.12.11	VIN #	REV.
FILE NAME: 14'LQ			
SCALE: 1:16	DATE PRINTED: 1/12/2011	SHEET 3 OF 5	

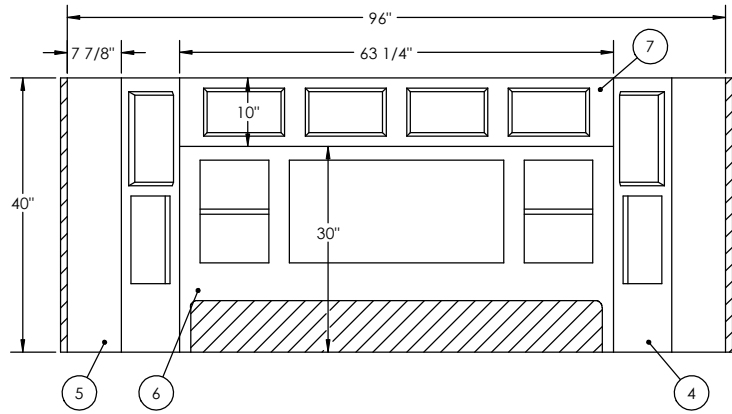

SECTION C-C

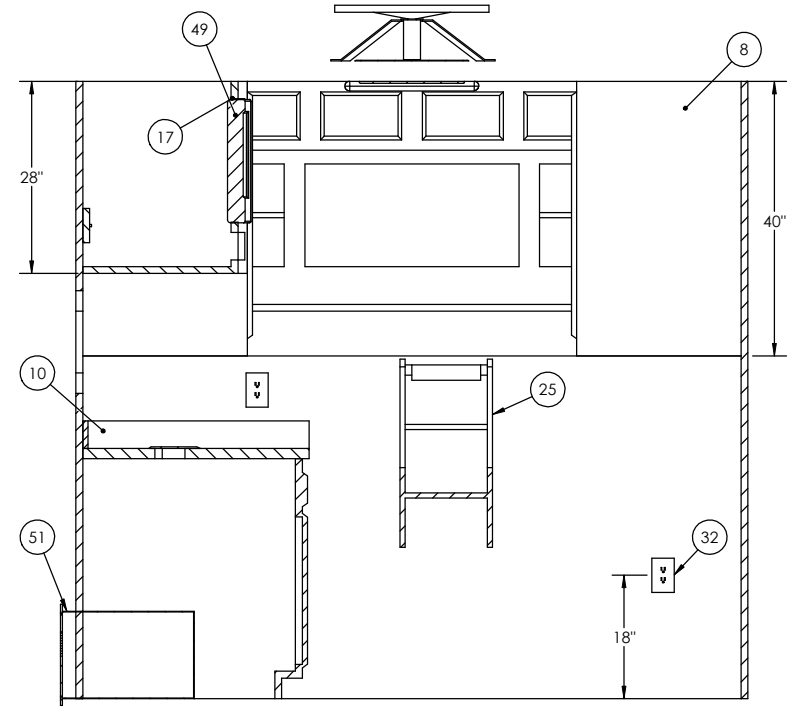

SECTION E-E

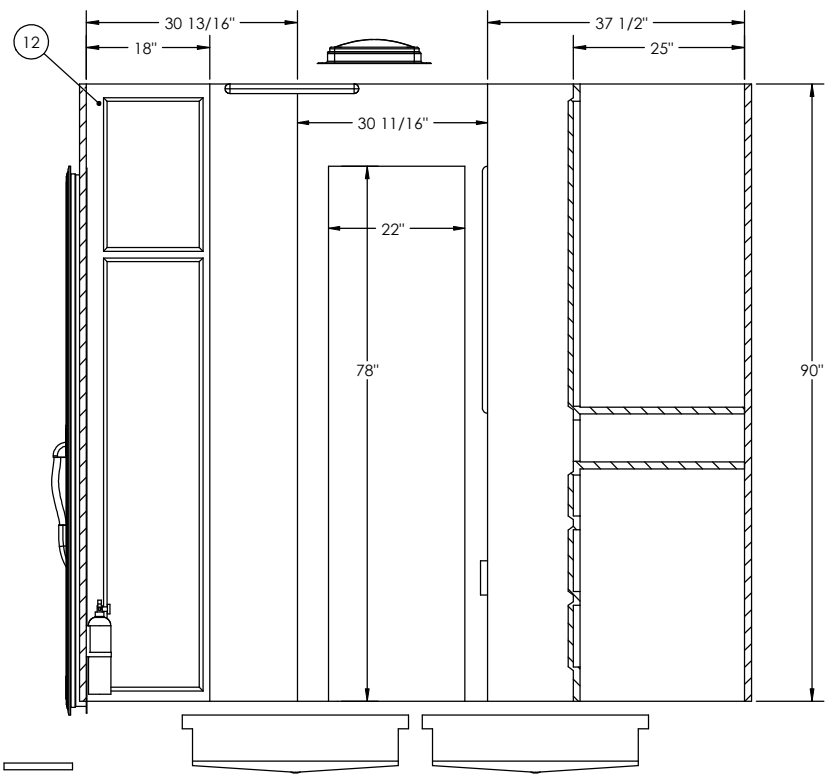

SECTION D-D



TITLE: 14' LQ PACKAGE			
DRAWN BY: JRS	DATE: 1.12.11	VIN #	REV.
FILE NAME: 14'LQ			
SCALE: 1:14	DATE PRINTED: 1/12/2011	SHEET 4 OF 5	

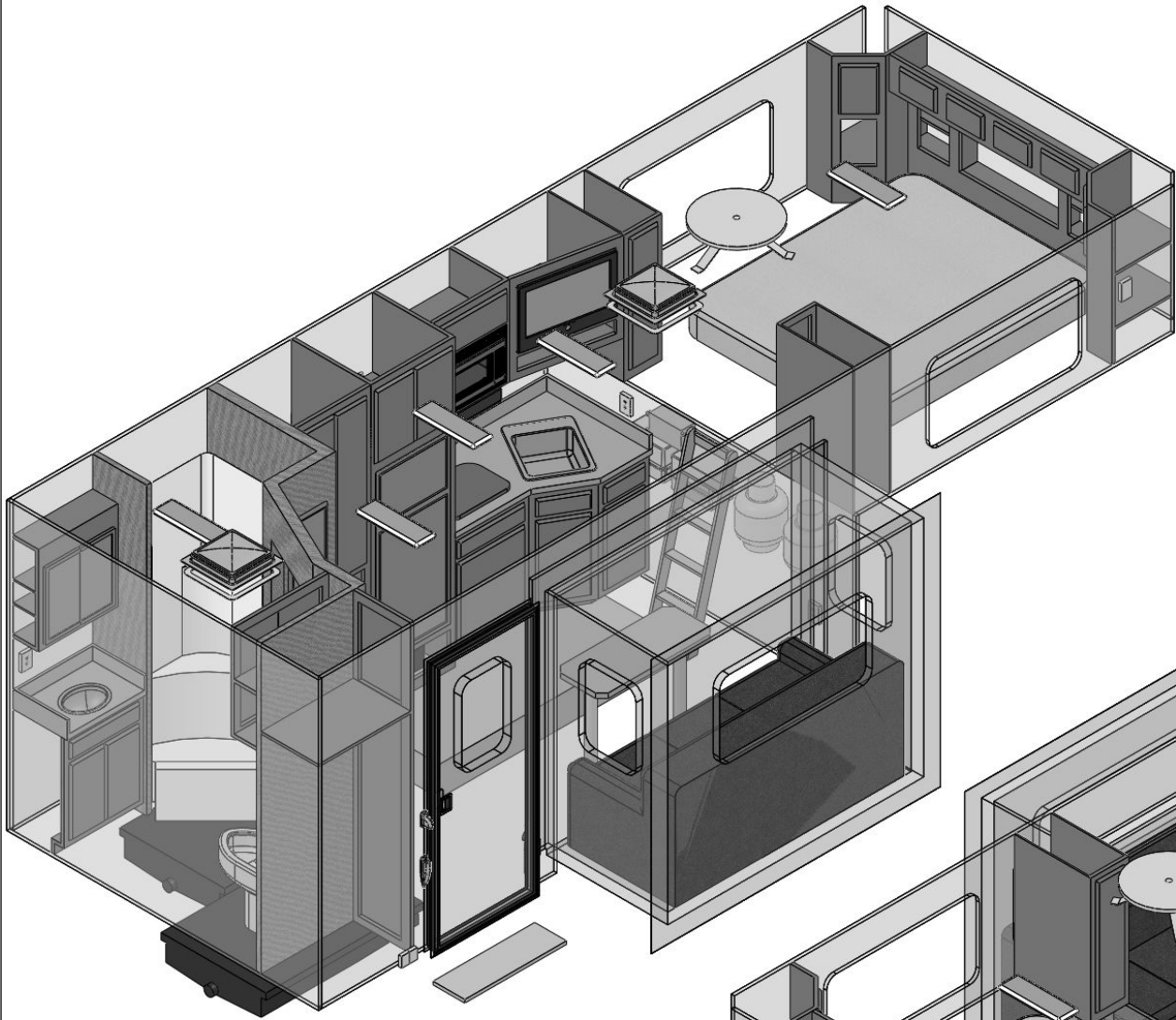

CURB SIDE VIEW

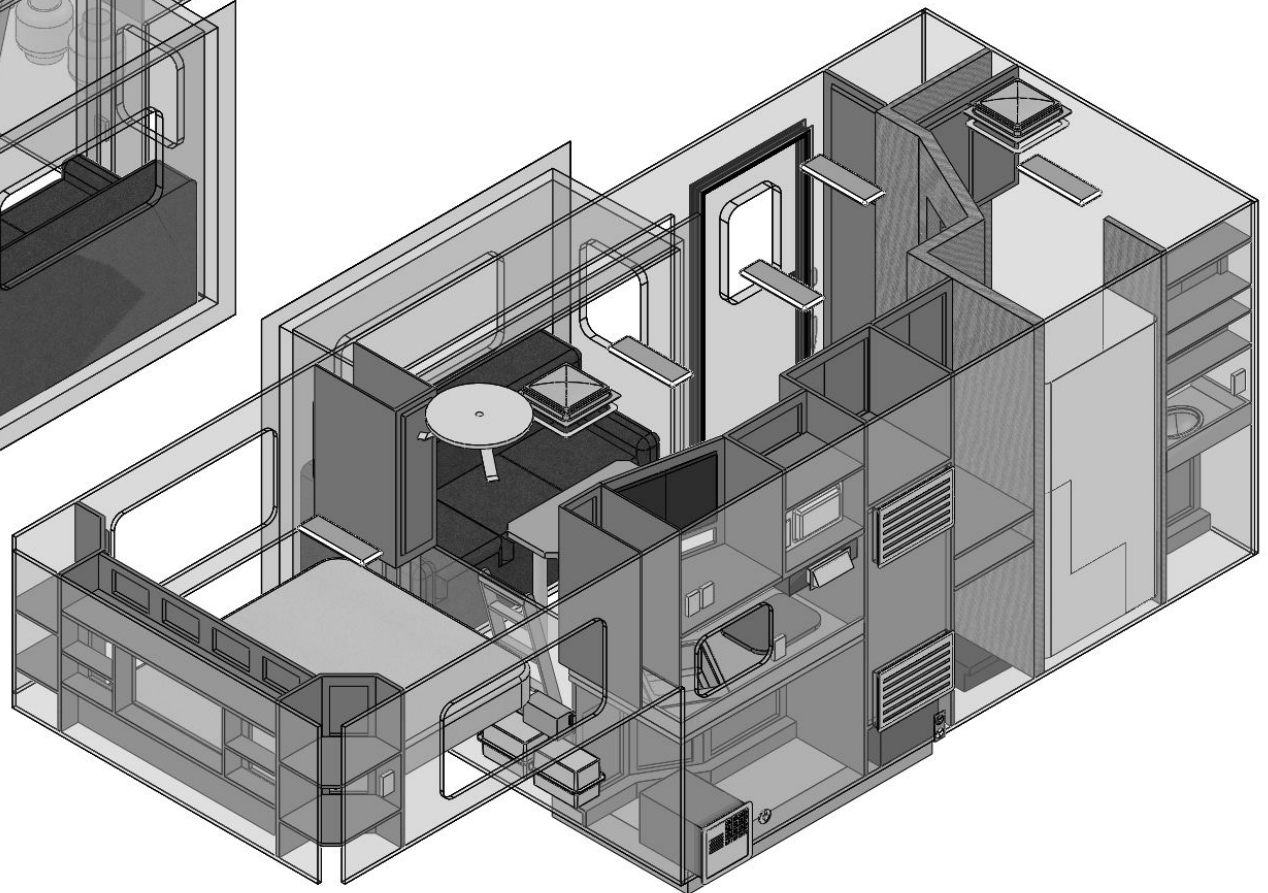

ROAD SIDE VIEW



TITLE: 14' LQ PACKAGE			
DRAWN BY: JRS	DATE: 1.12.11	VIN #	REV.
FILE NAME: 14'LQ			
SCALE: 1:20	DATE PRINTED: 1/12/2011	SHEET 5 OF 5	